

AMT1308
8 - 12GHz Multi-Function Chip

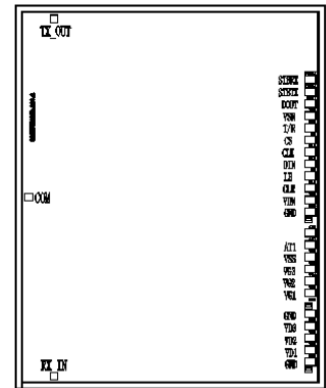

Key Features :

- Frequency range : 8 – 12GHz
- Receiver gain : 5dB
- Transmitter gain : 5.5dB
- Receiving, Transmitting P-1 : 12/12dBm
- Phase shift bit : 6 bits
- Phase shift step : 5.625°
- Phase shift RMS : 2.5°, phase shift additive attenuation ±1.5dB
- Attenuation bit : 6 bits
- Attenuation step : 0.5dB
- Attenuation RMS : 0.5dB, attenuation additive phase shift ±15°
- Input/Output Standing Wave : 1.5
- Operation voltage : VD1/VD2/VD3/VDN : 3.3V
- Operation voltage : VSN/VSS : -2.9V
- Control method : TTL, serial control
- Chip dimensions : 3.8mm x 4.7mm x 0.1mm
- Applications : wireless communication, transceiver module, radio telecommunication etc.

Description :

AMT1308 is a multi-function chip incorporating with amplifier, switch, 6-digit attenuator, 6-digit phase shifter, control driver etc. X band MMIC, using Gallium Arsenide (GaAs) pHEMT process. The chip uses dual voltage operation, control level is TTL, with serial control. This chip is designed with ground through metal vias on the back technology. All chip products p are 100% RF tested.

Absolute Maximum Ratings (Ta = 25°C)

Symbol	Parameter	Value	Remark
V _{CLK} /V _{CLR} /V _{CS} /V _{LE} /V _{T/R} /V _{DIN}	Control voltage	+7V	
VD1/VD2/VD3/VDN	Operation voltage	+7V	
VSN/VSS	Operation voltage	-6V	
Pin	Max. input signal power	+20dBm	
Tch	Operation Temperature	150°C	
Tm	Sintering Temperature	310°C	30s, N ₂ protection
Tstg	Storage Temperature	-65 ~ +150°C	

[1] Operation outside any of the Absolute Maximum Ratings may cause permanent device damage.

Electrical Characteristics (Ta = 25°C)

Symbol	Parameter	Value			Unit	Remark
		Min	Typical	Max		
F	Frequency	8 ~ 12			GHz	
G _R	Receiver gain	3	5	-	dB	
P _{-1R}	Receiver output at P-1 point	-	12	-	dBm	
NF	Noise figure	-	16	17	dB	
G _T	Transmitter gain	3	5.5	-	dB	
P _{-1T}	Transmitter output at P-1 point	-	12	-	dBm	
PS	Phase shift range	5.625 – 354.375 (6 bits phase shift)			°	
Δat	Phase shift additive attenuation variation	-1.5	-	+1.5	dB	
RMSp	Phase shift RMS	-	2.5	4	°	
ATT	Attenuation range	0.5 – 31.5 (6 bits attenuation)			dB	
Δph	Attenuation additive phase shift variation	-15	-	+15	°	
RMS _A	Attenuation RMS	-	0.5	0.8	dB	
VSWR	Input Output Standing Wave	-	1.5	1.8		
I _d	Operation current I _d	-	60	75	mA	
I _s	Operation current I _s	-	23	25	mA	

Typical Performance

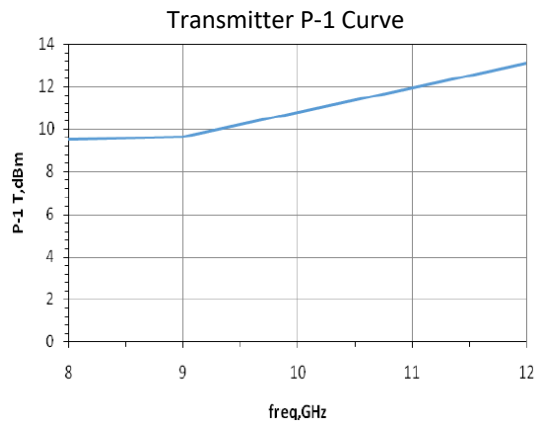
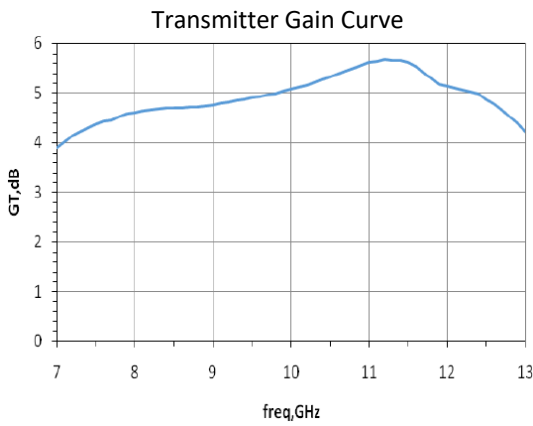
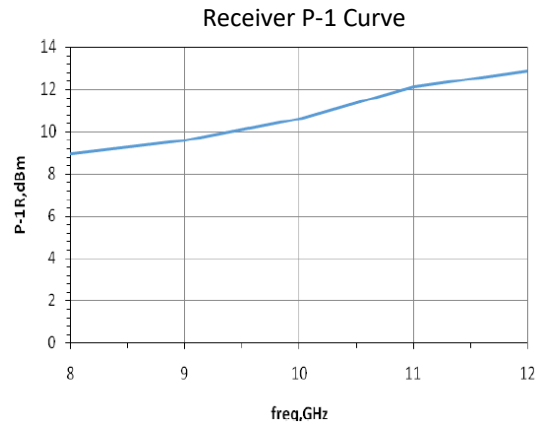
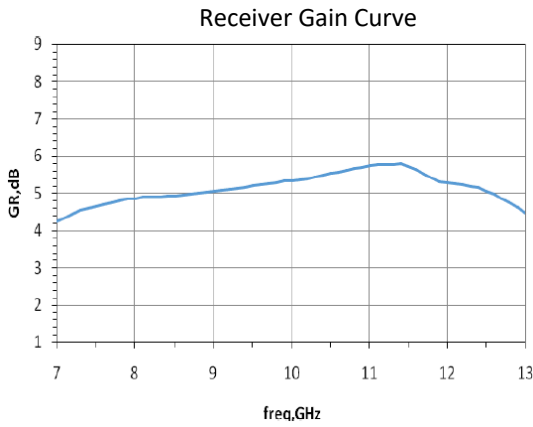

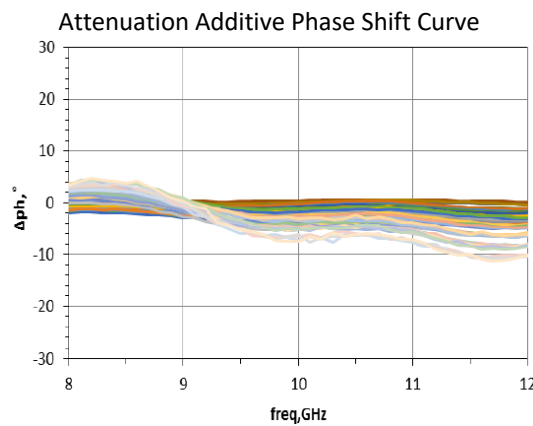
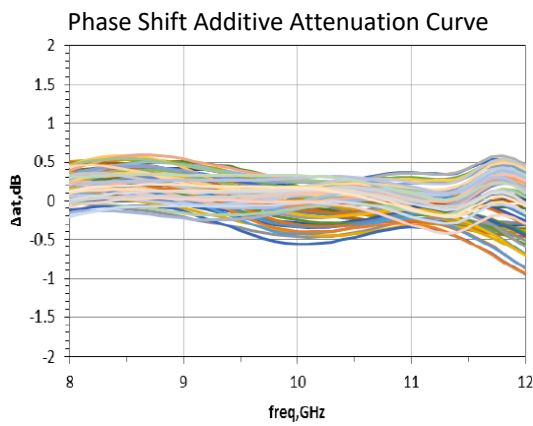
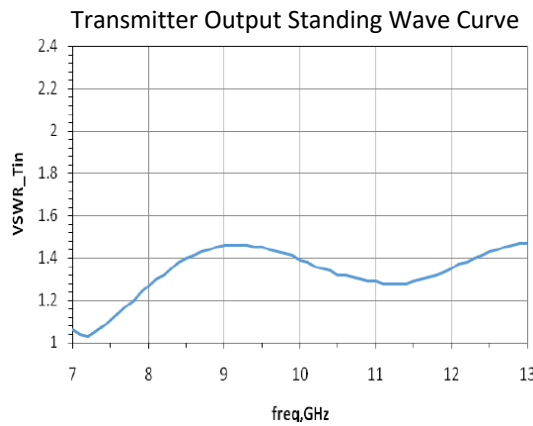
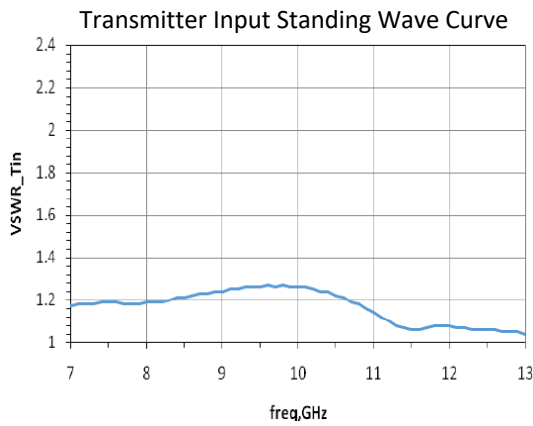
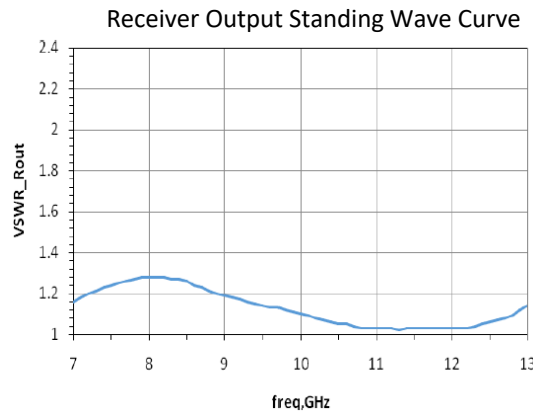
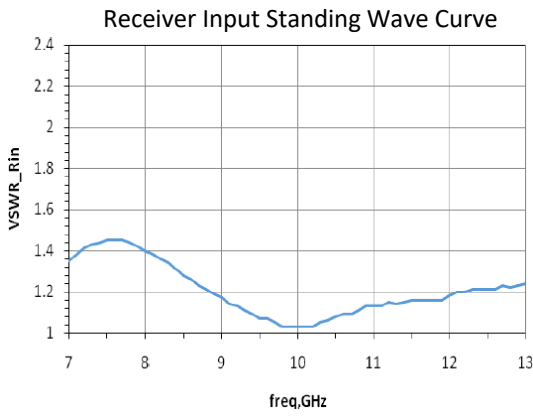
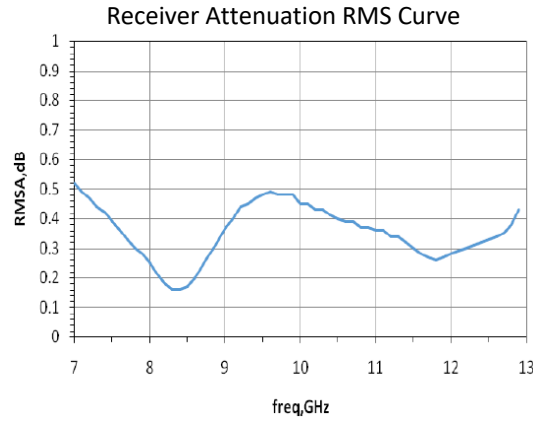
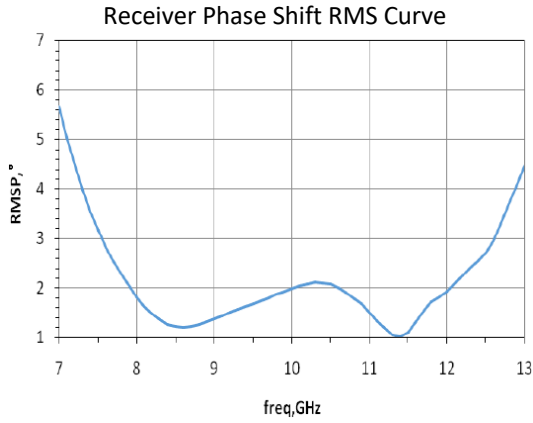

Internal Functional Block Diagram

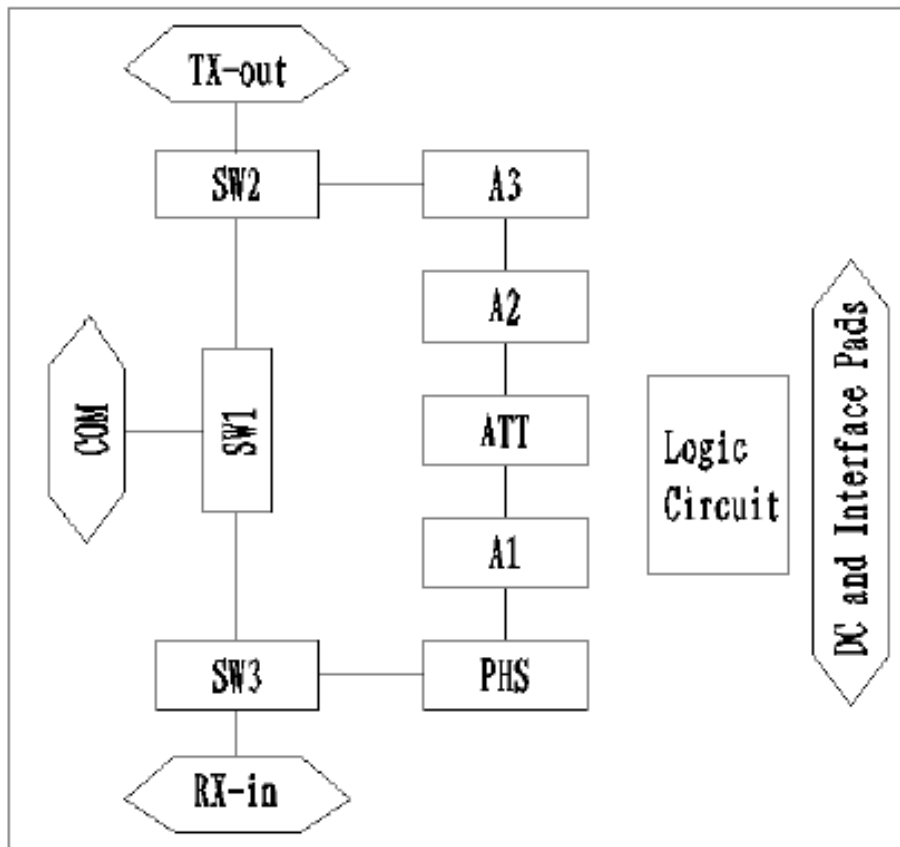

Chip Dimensions (Unit : μm)

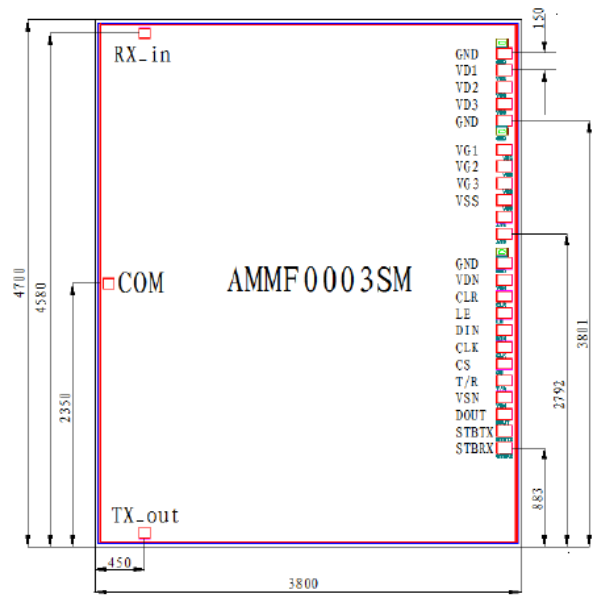
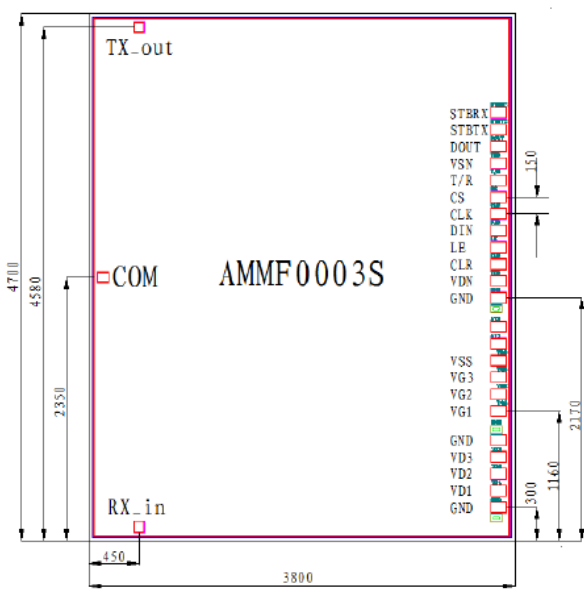

Chip Layout Diagram

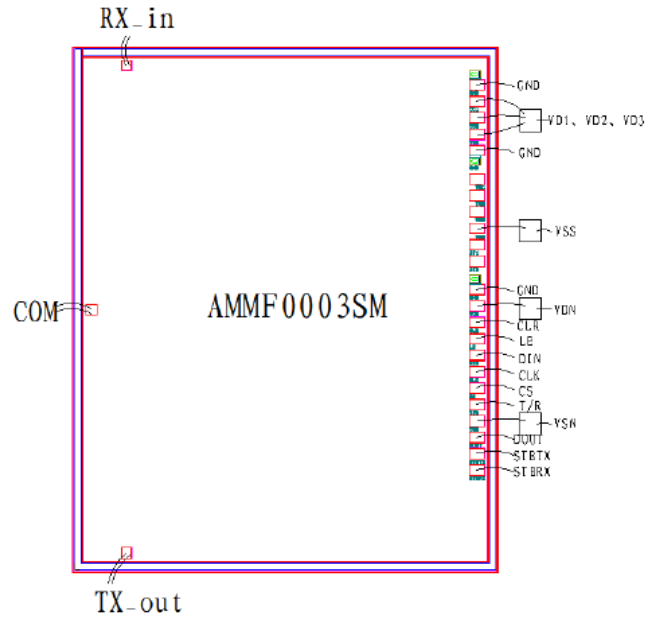
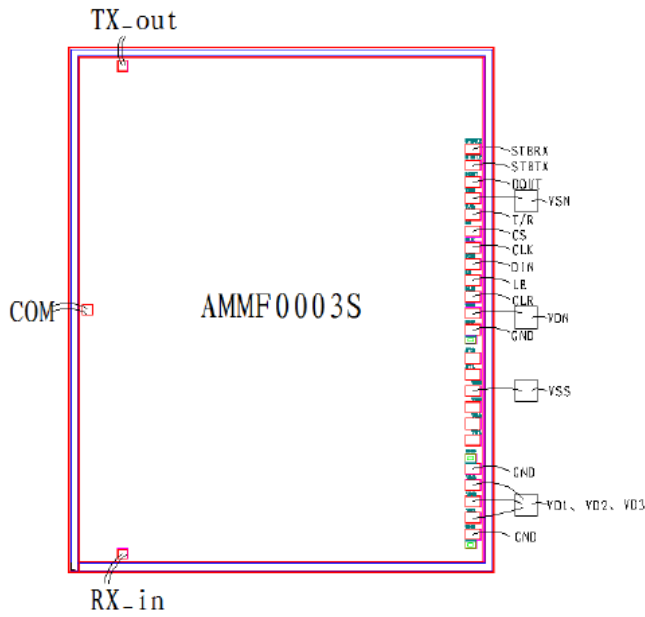

Solder Pad Definition

Name	Dimension	Remark
RX_in/TX_out	100µm x 100µm	Receive input/Transmit output
COM	100µm x 100µm	Receive output/Transmit input
STBRX/STBTX/DOUT	100µm x 140µm	TTL, output : Receive standby / Transmit standby / Serial control word
VSN/VSS/VDN/VD123	100µm x 140µm	Supply solder pad : -2.9V/-2.9V/+3.3V/+3.3V
CL/CLK/DIN/LE/TR	100µm x 140µm	TTL, control signal input, speed 40M
CLR	100µm x 140µm	TTL, reset signal input
VG1/VG2/VG3	100µm x 140µm	Can be floating. Gate voltage adjust solder pad, -0.4V ~ -1V
GND	100µm x 140µm	Ground

Control Descriptions

Signal Function Definition

No.	Signal	Level	Function		Remark
			"0"	"1"	
1	TR	Input (TTL level)	Receive	Transmit	Transmit, receive control signal
2	CS	Input (TTL level)	Add data	Keep data	Chip select signal, low level
3	CLK	Input (TTL level)	-	-	Clock signal, falling edge active
4	LE	Input (TTL level)	-	-	Data ready signal, rise edge active
5	DIN	Bit 0	Operate	Standby	Receive standby signal : operate means normal receive status
		Bit 1 ~ Bit 24	Off	On	Phase shift attenuation control signal : On means Shifter and Attenuator activate control
		Bit 25	Operate	Standby	Transmit standby signal : operate means normal transmit status
6	CLR	Input (TTL level)	-	-	Reset signal : power up 100ms low level, reset starts.
7	STBRX	Output (TTL level)	-	-	Receive standby signal
8	STBTX	Output (TTL level)	-	-	Transmit standby signal
9	DOUT	Output (TTL level)	-	-	Output DIN control signal : when new serial control word is sent into phase shift register, original control word stored in the register will output from DOUT port.

Timing

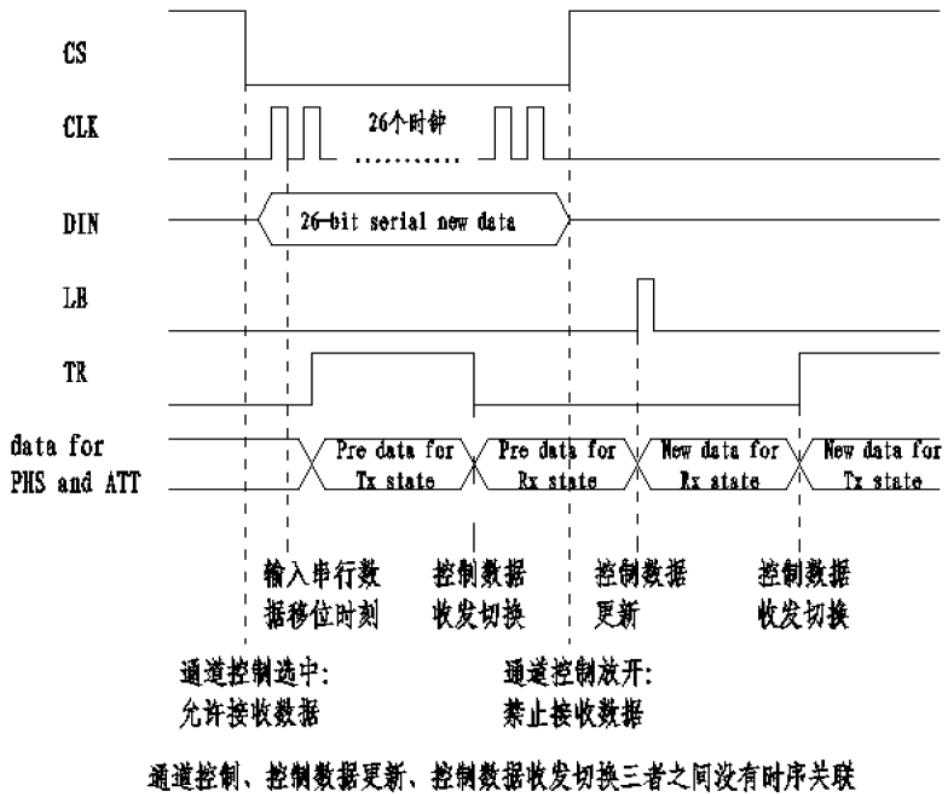

Serial Parallel Conversion Illustration

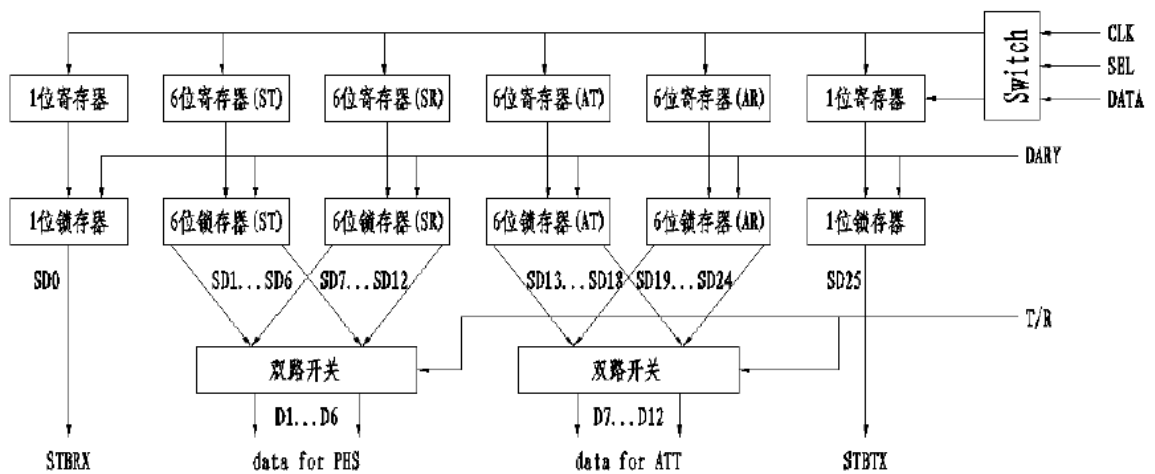

DIN Serial Control Word Definition

BIT	Description	
BIT0	Receive standby	STBRX output
BIT1	5.625°	Transmit phase shift
BIT2	11.25°	
BIT3	22.5°	
BIT4	45°	
BIT5	90°	
BIT6	180°	
BIT7	5.625°	Receive phase shift
BIT8	11.25°	
BIT9	22.5°	
BIT10	45°	
BIT11	90°	
BIT12	180°	
BIT13	0.5dB	Transmit attenuation
BIT14	1dB	
BIT15	2dB	
BIT16	4dB	
BIT17	8dB	
BIT18	16dB	
BIT19	0.5dB	Receive attenuation
BIT20	1dB	
BIT21	2dB	
BIT22	4dB	
BIT23	8dB	
BIT24	16dB	
BIT25	Transmit standby	STBTX output

Switch Truth Table

Bit 0	Bit 25	TR	COM-TX_out	COM-RX_in	COM_Load	Internal Amplifier Operation Status
0	0	0	Off	On	Off	Operating
0	0	1	On	Off	Off	Operating
0	1	0	Off	On	Off	Operating
0	1	1	Off	Off	Off	Operating
1	0	0	Off	Off	Off	Operating
1	0	1	On	Off	Off	Operating
1	1	0/1	Off	Off	On	Standby